

Basic Multi-rate Operations: Decimation and Interpolation

- Building blocks for traditional single-rate digital signal processing: multiplier (with a constant), adder, delay, multiplier (of 2 signals)

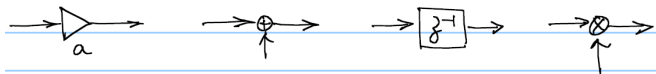

- New building blocks in multi-rate signal processing:

M -fold decimator

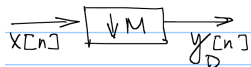

L -fold expander

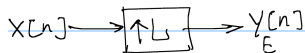

Readings: Vaidyanathan Book §4.1; tutorial Sec. II A, B

L-fold Expander

$$y_E[n] = \begin{cases} x[n/L] & \text{if } n \text{ is integer multiple of } L \in \mathbb{N} \\ 0 & \text{otherwise} \end{cases}$$

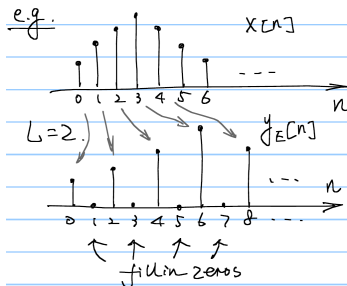
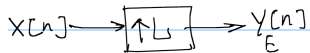

Question: Can we recover $x[n]$ from $y_E[n]$? \rightarrow Yes.

The expander does not cause loss of information.

Question: Are $\uparrow L$ and $\downarrow M$ linear and shift invariant?

Input-Output Relation on the Spectrum

$$Y_E(z) = X(z^L)$$

[\(details\)](#)

Evaluating on the unit circle, the Fourier Transform relation is:

$$Y_E(e^{j\omega}) = X(e^{j\omega L}) \Rightarrow Y_E(\omega) = X(\omega L)$$

i.e. L -fold compressed version of $X(\omega)$ along ω

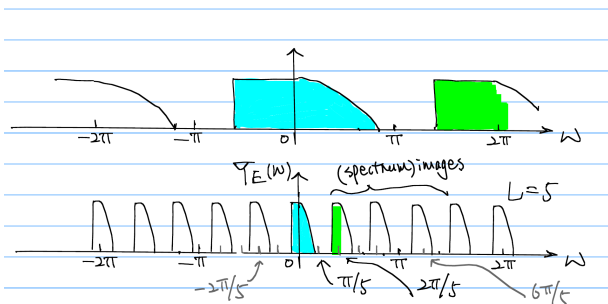

M-fold Decimator

$$y_D[n] = x[Mn], M \in \mathbb{N}$$

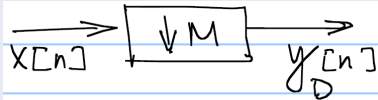

e.g. $M=2$

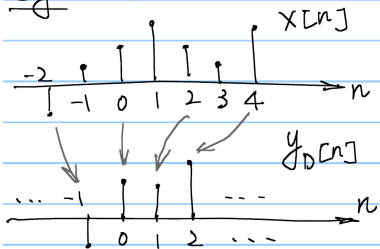

Corresponding to the physical time scale, it is as if we sampled the original signal in a slower rate when applying decimation.

Questions:

- What potential problem will this bring?
- Under what conditions can we avoid it?
- Can we recover $x[n]$?

Transform-Domain Analysis of Decimators

$$Y_D(z) = \sum_{n=-\infty}^{\infty} y_D[n]z^{-n} = \sum_{n=-\infty}^{\infty} x[nM]z^{-n}$$

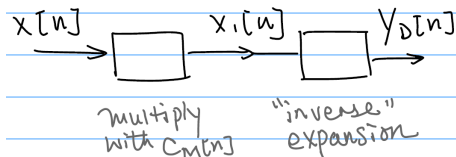

Putting all together:

$$Y_D(z) = \frac{1}{M} \sum_{k=0}^{M-1} X\left(W_M^k z^{\frac{1}{M}}\right)$$

(details)

$$Y_D(\omega) = \frac{1}{M} \sum_{k=0}^{M-1} X\left(\frac{\omega - 2\pi k}{M}\right)$$

(details)

Frequency-Domain Illustration of Decimation

Interpretation of $Y_D(\omega)$

Step-1: stretch $X(\omega)$ by a factor of M to
obtain $X(\omega/M)$

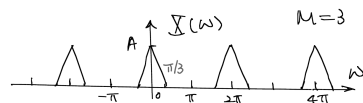

Step-2: create $M - 1$ copies and shift
them in successive amounts of 2π

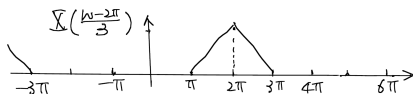
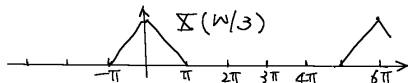

Step-3: add all M copies together and
multiply by $1/M$.

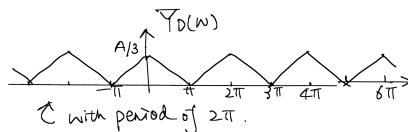
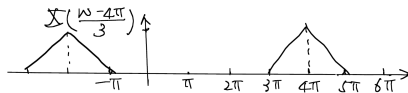

Interconnection of Building Blocks: Basic Properties

Basic interconnection properties:

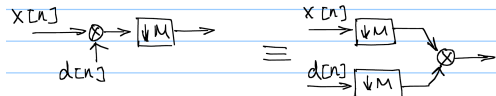
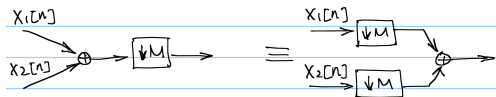
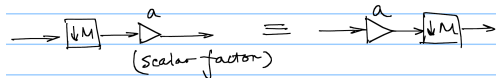

} by the linearity of $\downarrow M$ & $\uparrow L$

Readings: Vaidyanathan Book §4.2; tutorial Sec. II B

Decimator-Expander Cascades

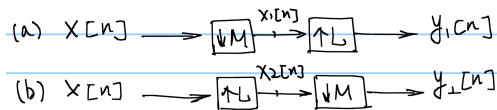

Questions:

1 Is $y_1[n]$ always equal to $y_2[n]$? Not always.

E.g., when $L = M$, $y_2[n] = x[n]$, but

$y_1[n] = x[n] \cdot c_M[n] \neq y_2[n]$, where $c_M[n]$ is a comb sequence

2 Under what conditions $y_1[n] = y_2[n]$?

Condition for $y_1[n] = y_2[n]$

Equiv. to examine the condition of $\{W_M^k\}_{k=0}^{M-1} \equiv \{W_M^{kL}\}_{k=0}^{M-1}$:

iff M and L are relatively prime.

Question: Prove it. (see homework).

Equivalent to show: $\{0, 1, \dots, M-1\} \equiv \{0, L, 2L, \dots, (M-1)L\} \pmod{M}$
iff M and L are relatively prime.

\Rightarrow Thus the outputs of the two decimator-expander cascades, $Y_1(z)$ and $Y_2(z)$, are identical and $(a) \equiv (b)$ **iff M and L are relatively prime**.

The Noble Identities

Consider a LTI digital filter with a transfer function $G(z)$:

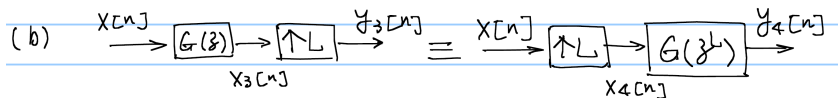
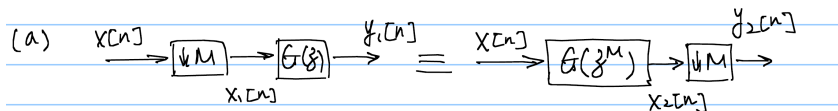

Question: What kind of impulse response will a filter $G(z^L)$ have?

Recall: the transfer function $G(z)$ of a LTI digital filter is rational for practical implementation, i.e., a ratio of polynomials in z or z^{-1} . There should not be terms with fractional power in z or z^{-1} .

Polyphase Representation: Definition

$$H(z) = \sum_{n=-\infty}^{\infty} h[2n]z^{-2n} + z^{-1} \sum_{n=-\infty}^{\infty} h[2n+1]z^{-2n}$$

Define $E_0(z)$ and $E_1(z)$ as two polyphase components of $H(z)$:

$$E_0(z) = \sum_{n=-\infty}^{\infty} h[2n]z^{-n},$$
$$E_1(z) = \sum_{n=-\infty}^{\infty} h[2n+1]z^{-n},$$

We have

$$H(z) = E_0(z^2) + z^{-1}E_1(z^2)$$

- These representations hold whether $H(z)$ is FIR or IIR, causal or non-causal.
- The polyphase decomposition can be applied to any sequence, not just impulse response.

Extension to M Polyphase Components

For a given integer M and $H(z) = \sum_{n=-\infty}^{\infty} h[n]z^{-n}$, we have:

$$H(z) = \sum_{n=-\infty}^{\infty} h[nM]z^{-nM} + z^{-1} \sum_{n=-\infty}^{\infty} h[nM + 1]z^{-nM} \\ + \dots + z^{-(M-1)} \sum_{n=-\infty}^{\infty} h[nM + M - 1]z^{-nM}$$

Type-1 Polyphase Representation

$$H(z) = \sum_{\ell=0}^{M-1} z^{-\ell} E_{\ell}(z^M)$$

where the ℓ -th polyphase components of $H(z)$ given M is

$$E_{\ell}(z) \triangleq \sum_{n=-\infty}^{\infty} e_{\ell}[n]z^{-n} = \sum_{n=-\infty}^{\infty} h[nM + \ell]z^{-n}$$

Note: $0 \leq \ell \leq (M - 1)$; strictly we may denote as $E_{\ell}^{(M)}(z)$.

Alternative Polyphase Representation

If we define $R_\ell(z) = E_{M-1-\ell}(z)$, $0 \leq \ell \leq M-1$, we arrive at the

Type-2 polyphase representation

$$H(z) = \sum_{\ell=0}^{M-1} z^{-(M-1-\ell)} R_\ell(z^M)$$

Type-1: $E_k(z)$ is ordered consistently with the number of delays in the input

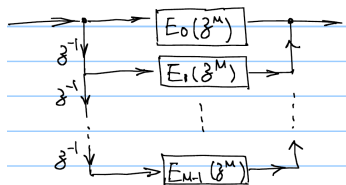

Type-2: reversely order the filter $R_k(z)$ with respect to the delays

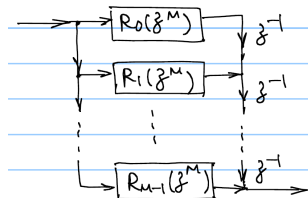

General Cases

In general, for FIR filters with length N :

M -fold decimation:

$$\text{MPU} = \frac{N}{M}, \text{APU} = \frac{N-1}{M}$$

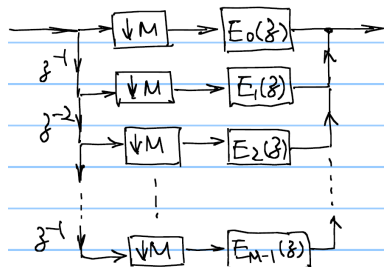

filtering is performed at a lower data rate

L -fold interpolation:

$$\text{MPU} = N, \text{APU} = N - L$$

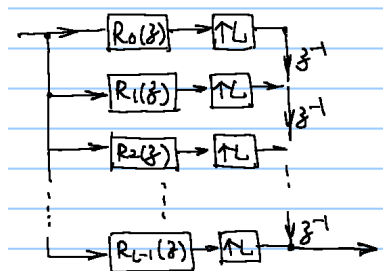

$$\text{APU} = \left(\frac{N}{L} - 1\right) \times L$$

Fractional Rate Conversion

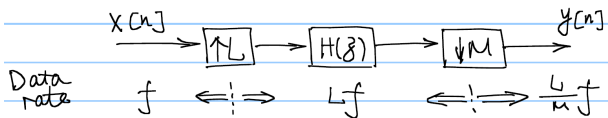

- Typically L and M should be chosen to have no common factors greater than 1 (o.w. it is wasteful as we make the rate higher than necessary only to reduce it down later)
- $H(z)$ filter needs to be fast as it operates in high data rate.
- The direct implementation of $H(z)$ is inefficient:
 - { there are $L - 1$ zeros in between its input samples
 - { only one out of M samples is retained

Multistage Decimation / Expansion

Similarly, for interpolation,

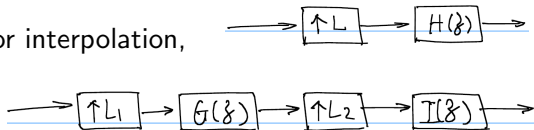

Summary

By implementing in multistage, not only the number of polyphase components reduces, but most importantly, the filter specification is less stringent and the overall order of the filters are reduced.

Exercises:

- Close book and think first how you would solve the problems.
- Sketch your solutions on your notebook.
- Then read V-book Sec. 4.4.

Digital Filter Banks

A digital filter bank is a collection of digital filters, with a common input or a common output.

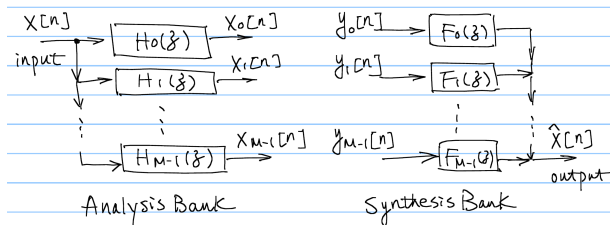

- $H_i(z)$: analysis filters
- $x_k[n]$: subband signals
- $F_i(z)$: synthesis filters
- SIMO vs. MISO

- Typical frequency response for analysis filters:

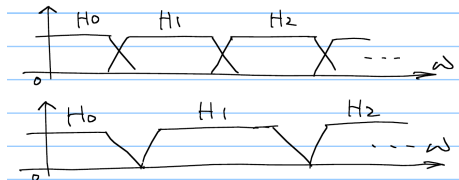

Can be

- marginally overlapping
- non-overlapping
- (substantially) overlapping

DFT Filter Bank

Consider passing $x[n]$ through a delay chain to get M sequences $\{s_i[n]\}$: $s_i[n] = x[n - i]$

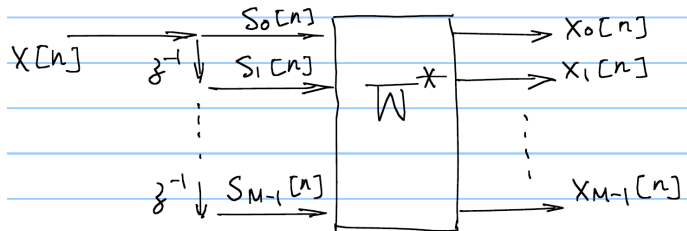

i.e., treat $\{s_i[n]\}$ as a vector $\underline{s}[n]$, then apply $W^* \underline{s}[n]$ to get $\underline{x}[n]$.
(W^* instead of W due to newest component first in signal vector)

Question: What are the equiv. analysis filters?
And if having a multiplicative factor α_i to the $s_i[n]$?

Uniform DFT Filter Bank

A filter bank in which the filters are related by

$$H_k(z) = H_0(zW^k)$$

is called a uniform DFT filter bank.

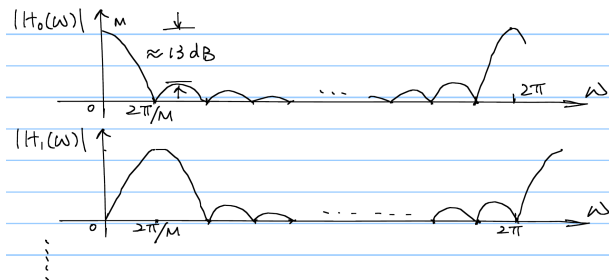

The response of filters $|H_k(\omega)|$ have a large amount of overlap.

Subband Coding

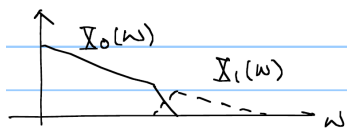
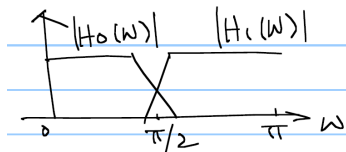

- 1 $x_0[n]$ and $x_1[n]$ are bandlimited and can be decimated
- 2 $X_1(\omega)$ has smaller power s.t. $x_1[n]$ has smaller dynamic range, thus can be represented with fewer bits

Suppose now to represent each subband signal, we need

$x_0[n]$: 16 bits / sample

$x_1[n]$: 8 bits / sample

$$\therefore 16 \times \frac{10k}{2} + 8 \times \frac{10k}{2} = 120\text{kbps}$$

2-Ch. QMF (a.k.a. Maximally Decimated Filter Bank)

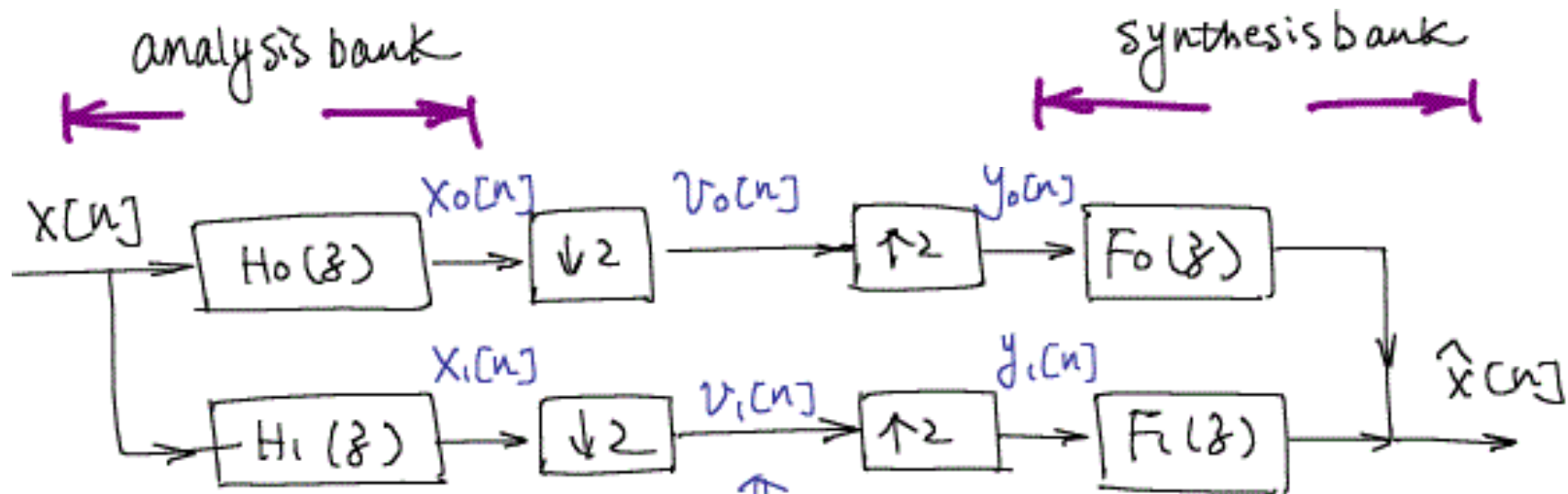

← decimated analysis bank →

⋮ ← "analysis part of the system" → ⋮ ← "synthesis part of the system" → ⋮

↖ In a broader sense to analysis/synthesis bank



Filter Bank for Subband Coding

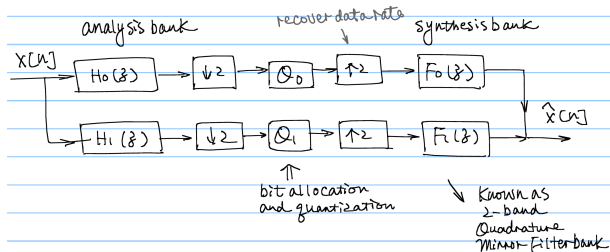

Role of $F_k(z)$:

- Eliminate spectrum images introduced by $\uparrow 2$, and recover signal spectrum over respective freq. range
- If $\{H_k(z)\}$ is not perfect, the decimated subband signals may have aliasing.
- $\{F_k(z)\}$ should be chosen carefully so that the aliasing gets canceled at the synthesis stage (in $\hat{x}[n]$).

Review: Quadrature Mirror Filter (QMF) Bank

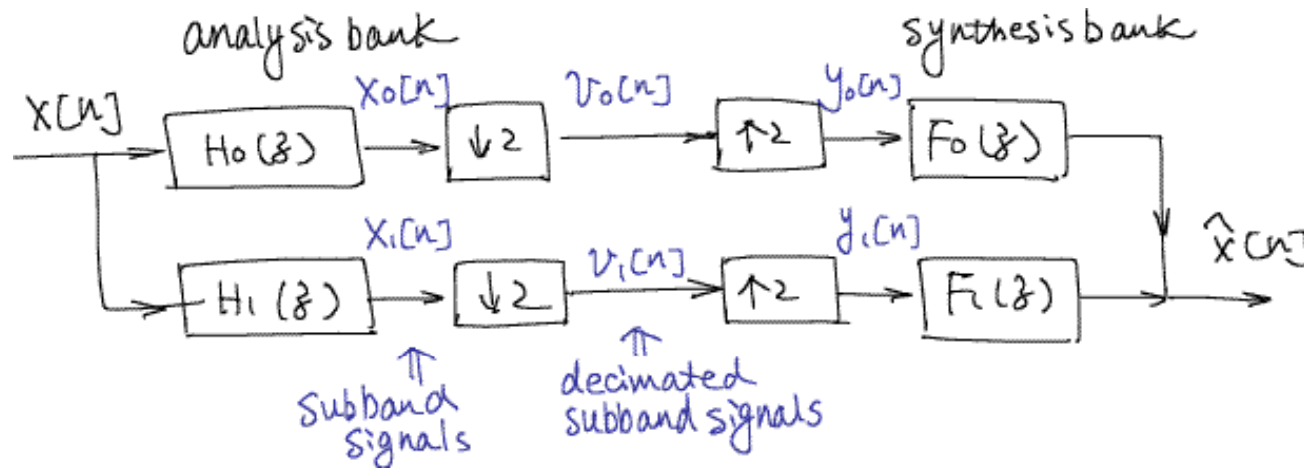

$$\begin{aligned}\hat{X}(z) &= F_0(z)Y_0(z) + F_1(z)Y_1(z) \\ &= \frac{1}{2} [H_0(z)F_0(z) + H_1(z)F_1(z)] X(z) \\ &\quad + \frac{1}{2} [H_0(-z)F_0(z) + H_1(-z)F_1(z)] X(-z)\end{aligned}$$

To cancel aliasing for all possible inputs $x[n]$,
s.t. $H_0(-z)F_0(z) + H_1(-z)F_1(z) = 0$,

we can choose

$$\begin{cases} F_0(z) = H_1(-z) \\ F_1(z) = -H_0(-z) \end{cases}$$



Polyphase Representation: Matrix Form

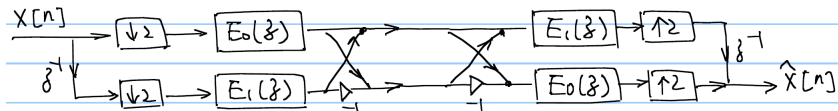

In matrix form: (with MIMO transfer function for intermediate stages)

$$\underbrace{\begin{bmatrix} E_1(z) & 0 \\ 0 & E_0(z) \end{bmatrix}}_{\text{synthesis}} \underbrace{\begin{bmatrix} 1 & 1 \\ 1 & -1 \end{bmatrix} \begin{bmatrix} 1 & 1 \\ 1 & -1 \end{bmatrix}}_{\begin{bmatrix} 2 & 0 \\ 0 & 2 \end{bmatrix}} \underbrace{\begin{bmatrix} E_0(z) & 0 \\ 0 & E_1(z) \end{bmatrix}}_{\text{analysis}}$$

$$= \begin{bmatrix} 2E_0(z)E_1(z) & 0 \\ 0 & 2E_0(z)E_1(z) \end{bmatrix}$$

* Note: Multiplication is from left for each stage when intermediate signals are in column vector form.

Summary

Many “wishes” to consider toward achieving alias-free P.R. QMF:

(0) alias free, (1) phase distortion, (2) amplitude distortion,
(3) desirable filter responses.

Can't satisfy them all at the same time, so often meet most of them and try to approximate/optimize the rest.

A particular relation of synthesis-analysis filters to cancel alias:

$$\begin{cases} F_0(z) = H_1(-z) \\ F_1(z) = -H_0(-z) \end{cases} \quad \text{s.t. } H_0(-z)F_0(z) + H_1(-z)F_1(z) = 0.$$

We considered a specific relation between the analysis filters:

$$H_1(z) = H_0(-z) \quad \text{s.t. response symmetric w.r.t. } \omega = \pi/2 \text{ (QMF)}$$

With polyphase structure: $T(z) = 2z^{-1}E_0(z^2)E_1(z^2)$

Summary: $T(z) = 2z^{-1}E_0(z^2)E_1(z^2)$

Case-1 $H_0(z)$ is FIR:

- P.R.: require polyphase components of $H_0(z)$ to be pure delay s.t. $H_0(z) = c_0z^{-2n_0} + c_1z^{-(2n_1+1)}$
[cons] $H_0(\omega)$ response is very restricted.
- For more desirable filter response, the system may not be P.R., but can minimize distortion:
 - eliminate phase distortion: choose filter order N to be odd, and $h_0[n]$ be symmetric (linear phase)
 - minimize amplitude distortion: $|H_0(\omega)|^2 + |H_1(\omega)|^2 \approx 1$

Case-2 $H_0(z)$ is IIR:

- $E_1(z) = \frac{1}{E_0(z)}$ can get P.R. but restrict the filter responses.
- eliminate amplitude distortion: choose polyphase components to be all pass, s.t. $T(z)$ is all-pass, but may have some phase distortion

M-ch. Maximally Decimated Filter Bank

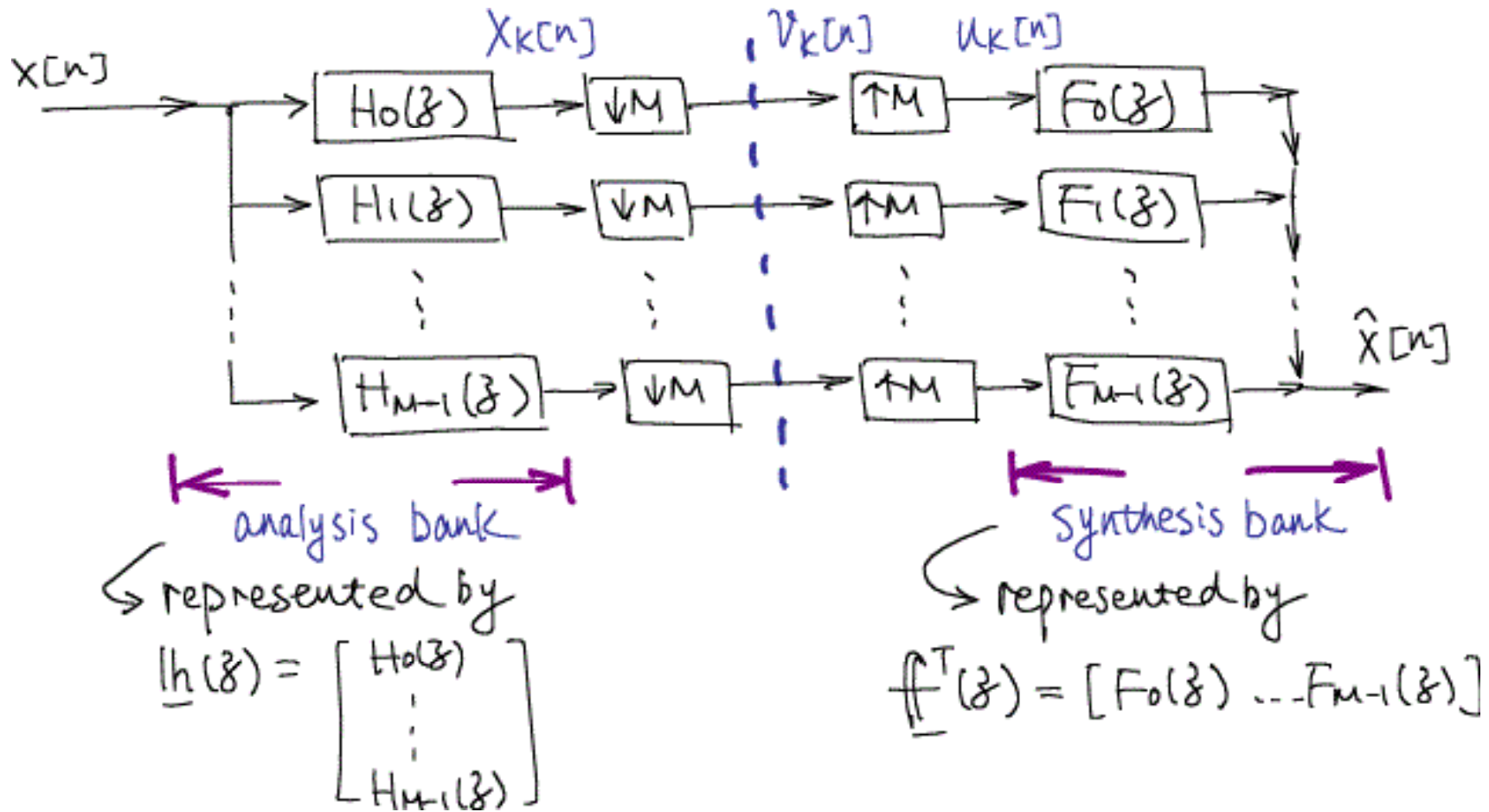

The Alias Component (AC) Matrix

From the definition of $A_\ell(z)$, we have in matrix-vector form:

$$\underbrace{M \begin{bmatrix} A_0(z) \\ A_1(z) \\ \vdots \\ A_{M-1}(z) \end{bmatrix}}_{\mathcal{A}(z)} = \underbrace{\begin{bmatrix} H_0(z) & H_1(z) & \dots & H_{M-1}(z) \\ H_0(zW) & H_1(zW) & \dots & H_{M-1}(zW) \\ \vdots & \vdots & \dots & \vdots \\ H_0(zW^{M-1}) & H_1(zW^{M-1}) & \dots & H_{M-1}(zW^{M-1}) \end{bmatrix}}_{\mathcal{H}(z)} \underbrace{\begin{bmatrix} F_0(z) \\ F_1(z) \\ \vdots \\ F_{M-1}(z) \end{bmatrix}}_{\underline{f}(z)}$$

$\mathcal{H}(z)$: $M \times M$ matrix called the “Alias Component matrix”

The condition for alias cancellation is

$$\mathcal{H}(z)\underline{f}(z) = \underline{t}(z), \quad \text{where } \underline{t}(z) = \begin{bmatrix} MA_0(z) \\ 0 \\ \vdots \\ 0 \end{bmatrix}$$

Review: Polyphase Implementation

UMCP ENEE631 Slides (created by M.Wu © 2004)

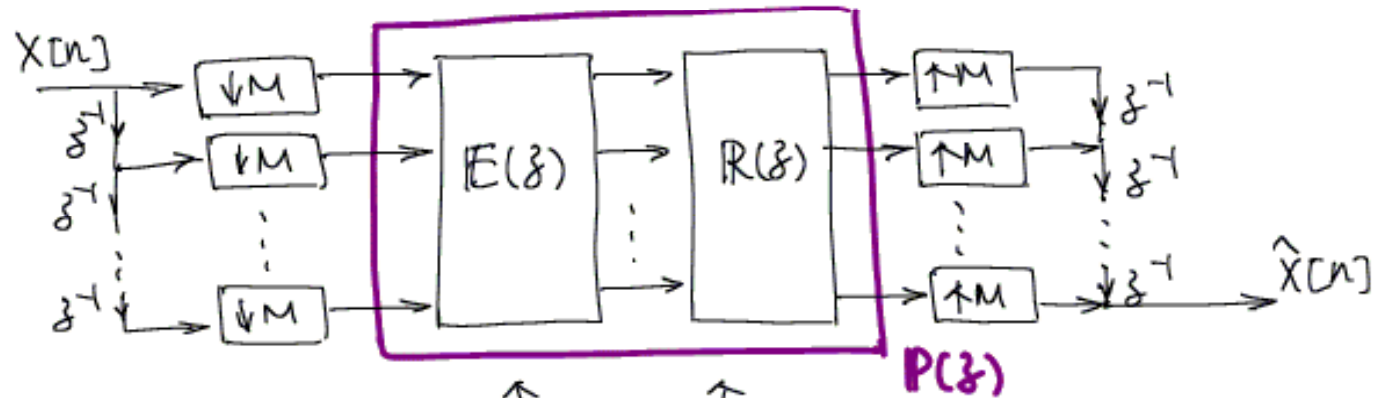
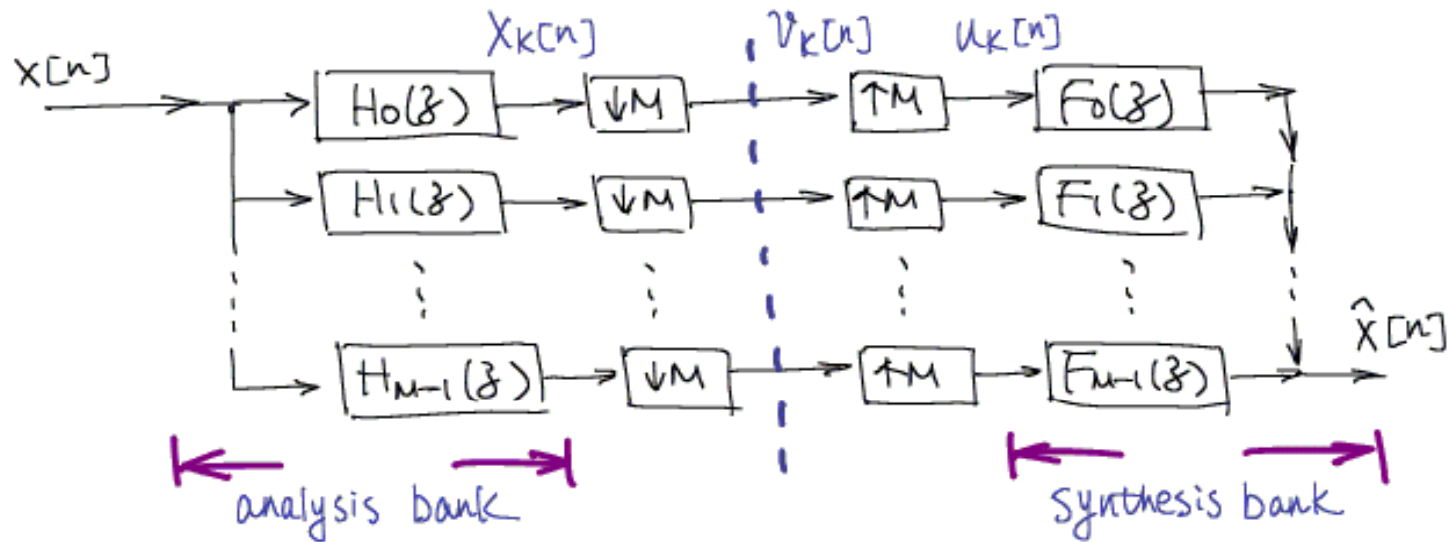

combine poly phase matrices into one matrix $P(z) = R(z)E(z)$.



Simple FIR P.R. Systems

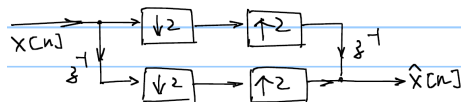

$$\hat{X}(z) = z^{-1}X(z),$$

i.e., transfer function $T(z) = z^{-1}$

Extend to M channels:

$$H_k(z) = z^{-k}$$

$$F_k(z) = z^{-M+k+1}, 0 \leq k \leq M-1$$

$$\Rightarrow \hat{X}(z) = z^{-(M-1)}X(z)$$

i.e. demultiplex then multiplex
again

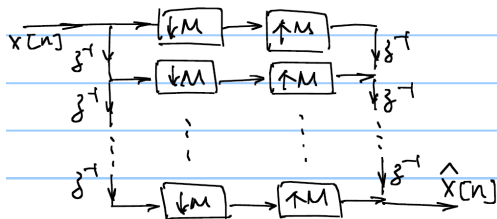

Perfect Reconstruction Filter Bank

UMCP ENEE630 Slides (created by M.Wu © 2010)

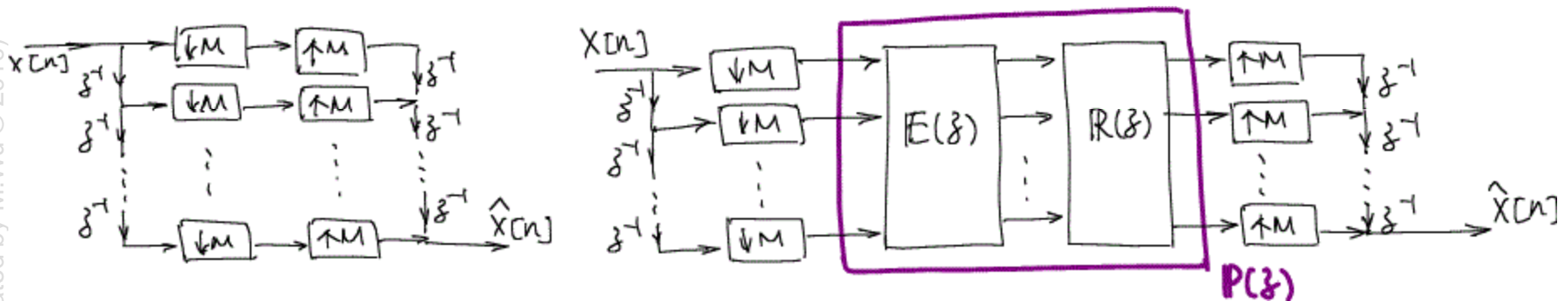

- If $\mathbf{P}(z) = \mathbf{R}(z)\mathbf{E}(z) = \mathbf{I}$, then the system is equivalent to the simple P.R. system on the left
 - If allowing $\mathbf{P}(z)$ to have some constant delay in practical design: i.e. $\mathbf{P}(z) = \mathbf{c} z^{-m_0} \mathbf{I}$
- ➔ System transfer function $\mathbf{T}(z) = \mathbf{c} z^{-(M m_0 + M - 1)}$



Dealing with Matrix Inversion

To satisfy $\mathbb{P}(z) = \mathbb{R}(z)\mathbb{E}(z) = \mathbb{I}$, it seems we have to do matrix inversion for getting the synthesis filters $\mathbb{R}(z) = (\mathbb{E}(z))^{-1}$.

Question: Does this get back to the same inversion problem we have with the viewpoint of the AC matrix $\underline{\mathbb{f}}(z) = \mathcal{H}^{-1}(z)\underline{\mathbb{t}}(z)$?

Solution:

- $\mathbb{E}(z)$ is a physical matrix that each entry can be controlled. In contrast, for $\mathcal{H}(z)$, only 1st row can be controlled (thus hard to ensure desired $H_k(z)$ responses **and** $\underline{\mathbb{f}}(z)$ stability)
- We can choose FIR $\mathbb{E}(z)$ s.t. $\det \mathbb{E}(z) = \alpha z^{-k}$ thus $\mathbb{R}(z)$ can be FIR (and has determinant of similar form).

Summary: With polyphase representation, we can choose $\mathbb{E}(z)$ to produce desired $H_k(z)$ and lead to simple $\mathbb{R}(z)$ s.t. $\mathbb{P}(z) = cz^{-k}\mathbb{I}$.

General Alias-free Condition

Recall from Section 7: The condition for alias cancellation in terms of $\mathcal{H}(z)$ and $\underline{f}(z)$ is

$$\mathcal{H}(z)\underline{f}(z) = \underline{t}(z) = \begin{bmatrix} MA_0(z) \\ 0 \\ \vdots \\ 0 \end{bmatrix}$$

Theorem

A M -channel maximally decimated filter bank is alias-free iff the matrix $\mathbb{P}(z) = \mathbb{R}(z)\mathbb{E}(z)$ is **pseudo circulant**.

[Readings: PPV Book 5.7]

Circulant and Pseudo Circulant Matrix

(right-)circulant matrix

$$\begin{bmatrix} P_0(z) & P_1(z) & P_2(z) \\ P_2(z) & P_0(z) & P_1(z) \\ P_1(z) & P_2(z) & P_0(z) \end{bmatrix}$$

Each row is the right circular shift of previous row.

pseudo circulant matrix

$$\begin{bmatrix} P_0(z) & P_1(z) & P_2(z) \\ z^{-1}P_2(z) & P_0(z) & P_1(z) \\ z^{-1}P_1(z) & z^{-1}P_2(z) & P_0(z) \end{bmatrix}$$

Adding z^{-1} to elements below the diagonal line of the circulant matrix.

- Both types of matrices are determined by the 1st row.
- Properties of pseudo circulant matrix (or as an alternative definition):
Each column as up-shift version of its right column with z^{-1} to the wrapped entry.

Insights of the Theorem

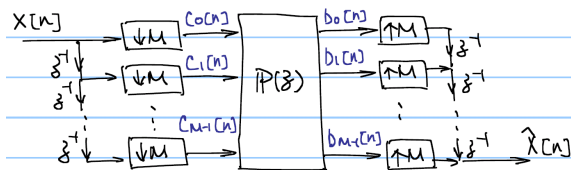

Denote $\mathbb{P}(z) = [P_{s,\ell}(z)]$.

(Details) For further exploration: See PPV Book 5.7.2 for detailed proof.

Examine the relation between $\hat{X}(z)$ and $X(z)$, and evaluate the gain terms on the aliased versions of $X(z)$.

Overall Transfer Function

The overall transfer function $T(z)$ after aliasing cancellation:

$\hat{X}(z) = T(z)X(z)$, where

$$T(z) = z^{-(M-1)} \{P_{0,0}(z^M) + z^{-1}P_{0,1}(z^M) + \cdots + z^{-(M-1)}P_{0,M-1}(z^M)\}$$

(Details) For further exploration: See PPV Book 5.7.2 for derivations.

Most General P.R. Conditions

Necessary and Sufficient P.R. Conditions

$$\mathbb{P}(z) = cz^{-m_0} \begin{bmatrix} 0 & \mathbb{I}_{M-r} \\ z^{-1}\mathbb{I}_r & 0 \end{bmatrix} \text{ for some } r \in 0, \dots, M-1.$$

When $r = 0$, $\mathbb{P}(z) = \mathbb{I} \cdot cz^{-m_0}$, as the sufficient condition seen in §1.7.3.

(Details)

(Binary) Tree-Structured Filter Bank

A multi-stage way to build M -channel filter bank:

Split a signal into 2 subbands \Rightarrow further split one or both subband signals into 2 $\Rightarrow \dots$

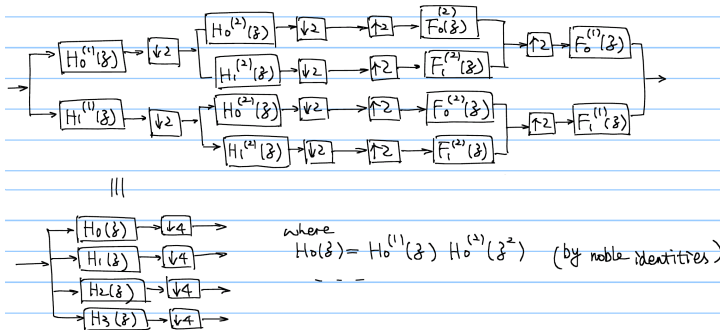

Question: Under what conditions is the overall system free from aliasing? How about P.R.?

(Binary) Tree-Structured Filter Bank

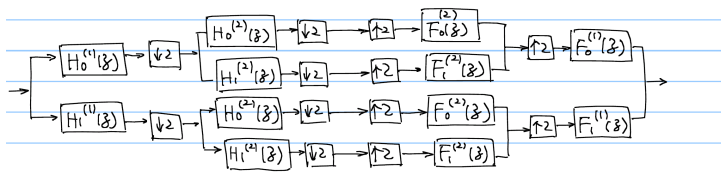

- Can analyze the equivalent filters by noble identities.
- If a 2-channel QMF bank with $H_0^{(K)}(z)$, $H_1^{(K)}(z)$, $F_0^{(K)}(z)$, $F_1^{(K)}(z)$ is alias-free, the complete system above is also alias-free.
- If the 2-channel system has P.R., so does the complete system.

[Readings: PPV Book 5.8]

Multi-resolution Analysis: Analysis Bank

Consider the variation of the tree structured filter bank (i.e., only split one subband signals)

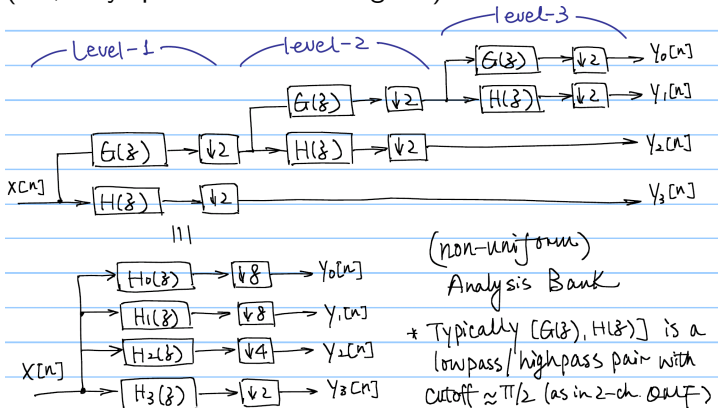

$$H_0(z) = G(z)G(z^2)G(z^4) \Rightarrow H_0(\omega) = G(\omega)G(2\omega)G(2^2\omega)$$

Multi-resolution Analysis: Synthesis Bank

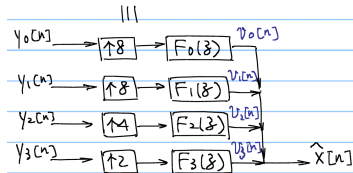
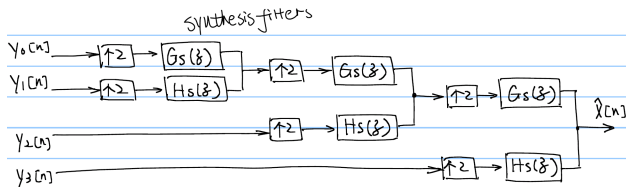

Synthesis Bank

* $\{v_k[n]\}$ have the same sampling rate as $x[n]$ and $\hat{x}[n]$

They are called the multiresolution components.

Discussions

(1) The typical frequency response of the equivalent analysis and synthesis filters are:

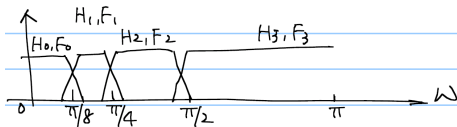

(2) The multiresolution components $v_k[n]$ at the output of $F_k(z)$:

- $v_0[n]$ is a lowpass version of $x[n]$ or a “coarse” approximation;
- $v_1[n]$ adds some high frequency details so that $v_0[n] + v_1[n]$ is a finer approximation of $x[n]$;
- $v_3[n]$ adds the finest ultimate details.

Discussions

(3) If 2-ch QMF with $G(z)$, $F(z)$, $G_s(z)$, $F_s(z)$ has P.R. with unit-gain and zero-delay, we have $x[n] = x[n]$.

(4) For compression applications: can assign more bits to represent the coarse info, and the remaining bits (if available) to finer details by quantizing the refinement signals accordingly.

Brief Note on Subband vs Wavelet Coding

- The **octave (dyadic)** frequency partition can reflect the **logarithmic** characteristics in human perception.
- Wavelet coding and subband coding have many similarities (e.g. from filter bank perspectives)
 - Traditionally subband coding uses filters that have little overlap to isolate different bands
 - Wavelet transform imposes smoothness conditions on the filters that usually represent a set of basis generated by shifting and scaling (dilation) of a mother wavelet function
 - Wavelet can be motivated from overcoming the poor time-domain localization of short-time FT

⇒ Explore more in Proj#1. See PPV Book Chapter 11